

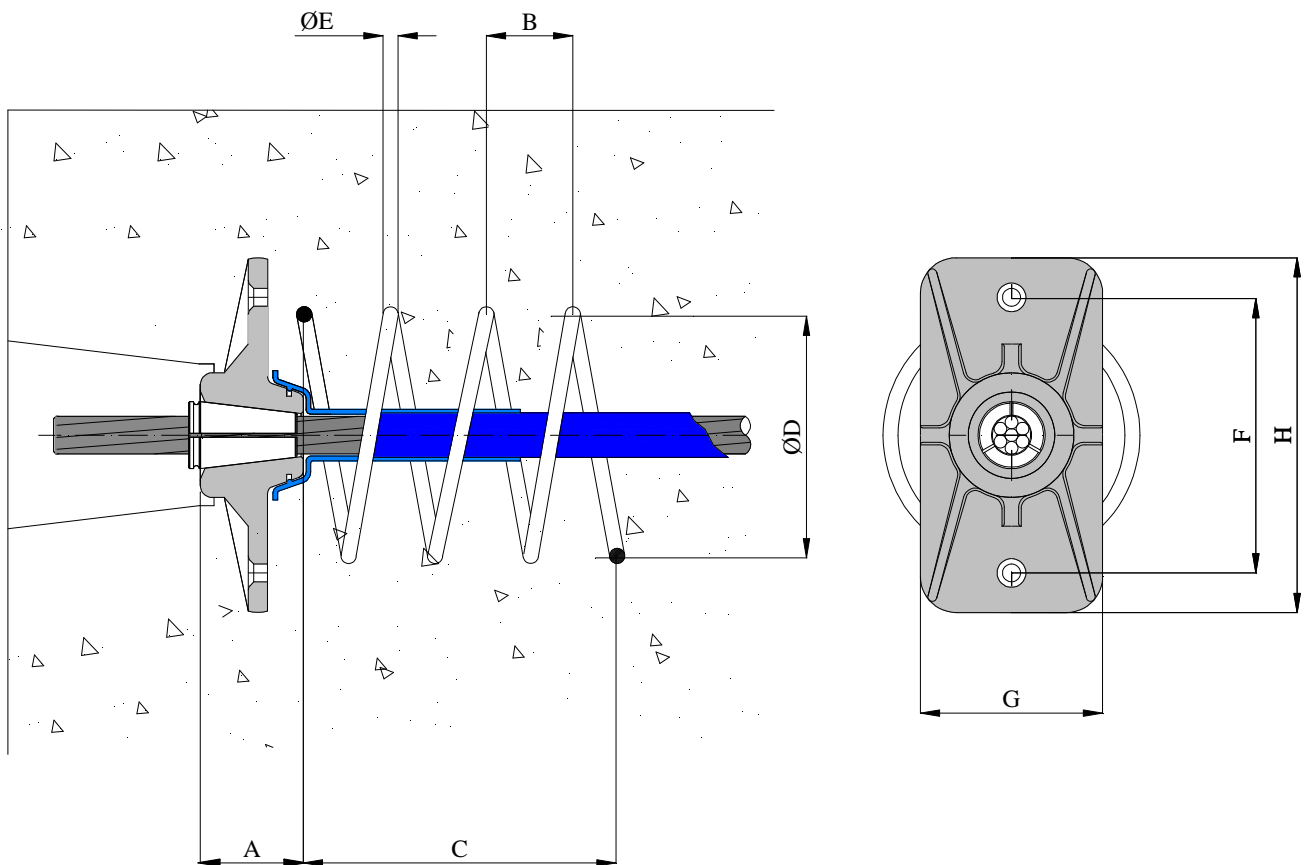

"E" series 1E15-A1 single strand anchorages
(Unbonded post-tensioning)



The anchorage: **active and unbonded, "1E15-A1" type**. It is supplied with a connection with the greased strand covered in polyethylene, the corrosion protection is provided by means of passivation while grouting. This application is typical for floors, diaphragms and slabs. The **"1E15-A1"** anchorage is unbonded, it may be supplied active (tensioning side) with truncated cone or rectangular pocket former to connect to the formwork.



Type	Ultimate load			A	B	C	D	E	F	G	H
	T15 for cable (kN)	T15S for cable (kN)	T15C for cable (kN)								
1E15-A1	259	279	307	43	40	130	110	6	115	76	148

"EX" series 1EX15-A2 single strand anchorages
(Unbonded encapsulated post-tensioning)



The anchorage: **active, unbonded and encapsulated, "1EX15-A2" type**. It is made with the total encapsulation of the polyethylene covered anchorage, with the greased strand covered in polyethylene. The **"1EX15-A2"** anchorage is unbonded, it is supplied active (tensioning side) with truncated cone or rectangular pocket former to connect to the formwork. It is provided with a pressure cap that may be installed after the strand, which is filled with grease, is cut. This application is typical of industrial floors, diaphragms or slabs in a highly aggressive environment for the whole system.

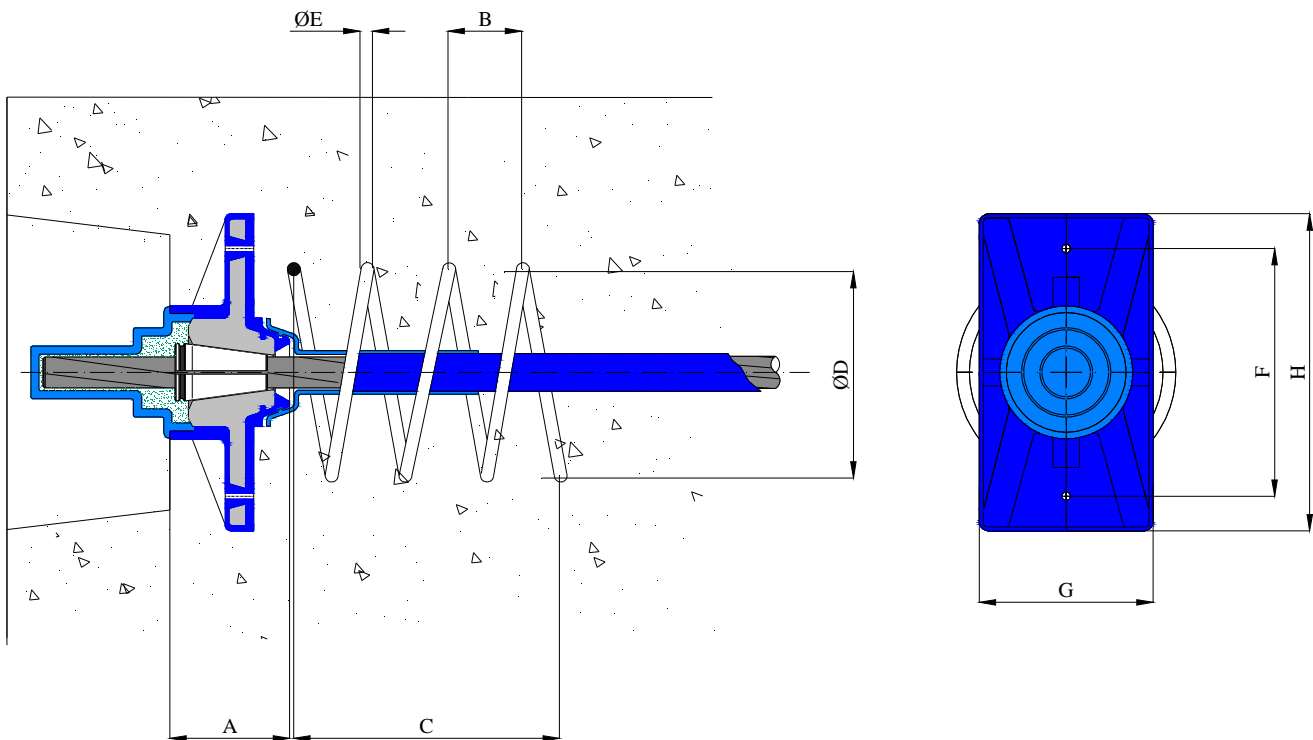

Type	Ultimate load			A	B	C	D	E	F	G	H
	T15 for cable (kN)	T15S for cable (kN)	T15C for cable (kN)								
1EX15-A2	259	279	307	60	40	130	110	6	130	85	155

"EXD" series 1EXD15-A3 single strand anchorages
(Unbonded encapsulated post-tensioning)



The anchorage: **active, unbonded and encapsulated, "1EX15-A3" type**. It is made with the total encapsulation of the polyethylene covered anchorage, with the greased strand covered in polyethylene. The "1EX15-A3" anchorage is unbonded, it is supplied active (tensioning side) with truncated cone or rectangular pocket former to connect to the formwork. This application is typical of industrial floors, diaphragms or slabs in a highly aggressive environment for the whole system. The anchorage is provided with a threaded closing tip in order to guarantee a stronger closure, it may be supplied assembled and properly greased, it is provided with spring locking and can be installed on site by qualified technicians.

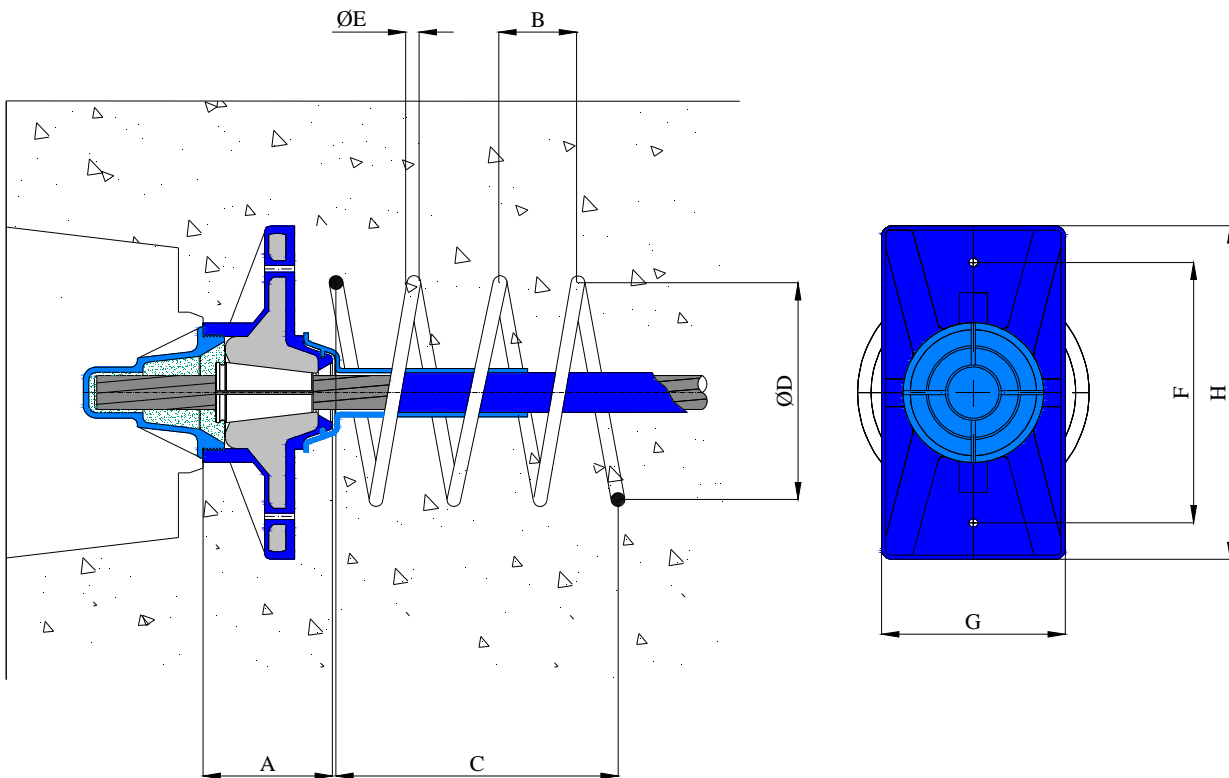

Type	Ultimate load			A	B	C	D	E	F	G	H
	T15 for cable (kN)	T15S for cable (kN)	T15C for cable (kN)								
1EXD15-A3	259	279	307	60	40	130	110	6	130	85	155

"ED" series 1ED15-A4 single strand anchorages
(Unbonded post-tensioning)



The anchorage: **active and unbonded, "1ED15-A4" type**. It is supplied with the greased strand covered in polyethylene. This application is typical for floors, diaphragms and slabs, where a simple anchorage protection is required by means of passivation while grouting. The "1E15-A1" anchorage is unbonded, it may be supplied active (tensioning side) with truncated cone or rectangular pocket former to connect to the formwork. The "1ED15-A4" unbonded anchorage is provided with a threaded closing tip in order to guarantee a stronger closure, it may be supplied assembled and properly greased, it is provided with spring locking and can be installed on site by qualified technicians.

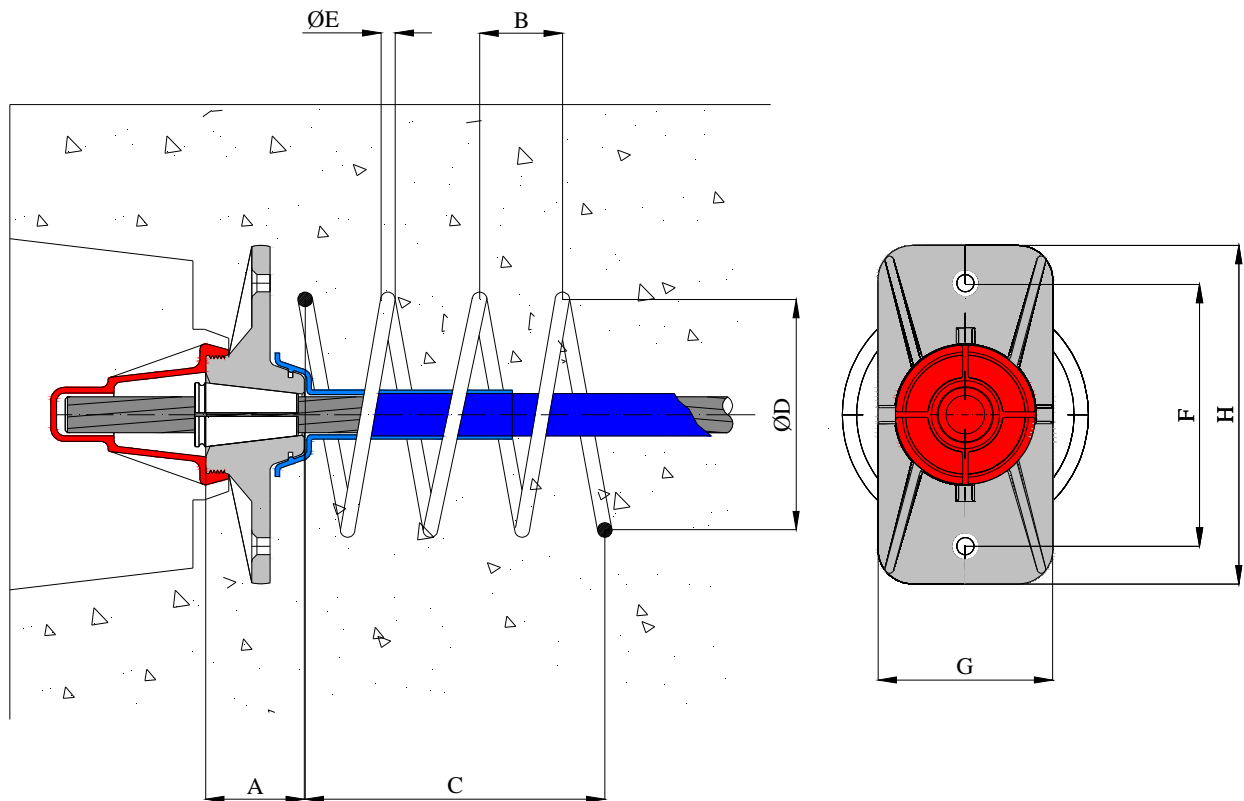

Type	Ultimate load			A	B	C	D	E	F	G	H	I
	T15 for cable (kN)	T15S for cable (kN)	T15C for cable (kN)									
1ED15-A4	259	279	307	43	40	130	110	6	115	76	148	77.5

“E” series 1E15-A5 single strand anchorages
(Bonded post-tensioning)



The anchorage: **active and bonded "1E15-A5"**. Its application allows to install bonded single strand anchorages with the strand entered into a metallic sheath, for an environment which requires a simple protection for the anchorage and the whole cable by means of passivation while grouting. The application is typical of industrial floors, diaphragms or slabs in a normal environment. This solution requires special tensioning jacks that can operate on a continuous cable. The cable is provided with a steel protection sheath, which must be provided with proper grouting and vent points.

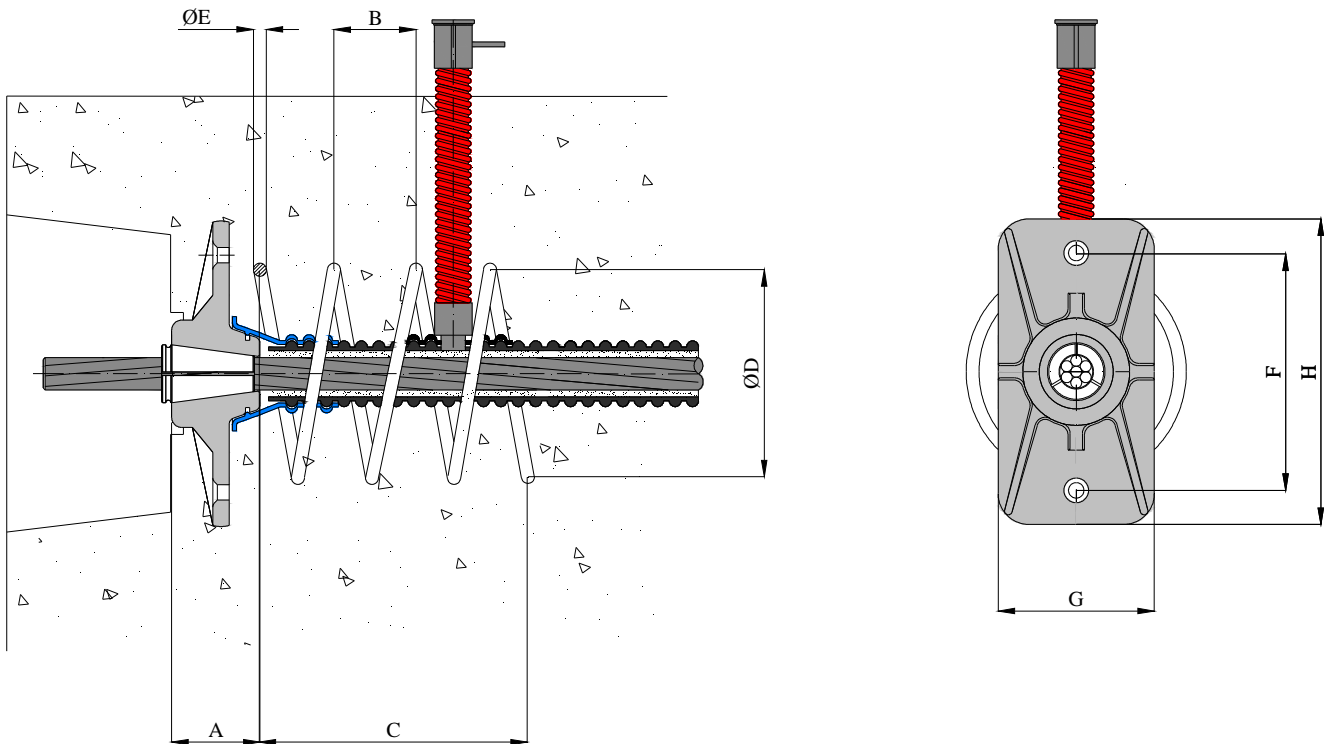

Type	Ultimate load			A	B	C	D	E	F	G	H
	T15 for cable (kN)	T15S for cable (kN)	T15C for cable (kN)								
1E15-A5	259	279	307	43	40	130	110	6	115	76	148

"EX" series 1EX15-A6 single strand anchorages
(Bonded post-tensioning)



The **active, bonded and encapsulated "1EX15-A6"** anchorage is made with the total encapsulation of the anchorage and of the cable, protected with a polyethylene corrugated sheath. The **"1EX15-A6"** anchorage is bonded and grouted, it is supplied active (tensioning side) with truncated cone or rectangular pocket former to connect to the formwork. This application is typical of industrial floors, diaphragms or slabs in a highly aggressive environment for the whole system. The anchorage is provided with a pressure cap that may be installed after the strand, which is filled with grease, is cut. The cable must be provided with proper grouting and vent points.

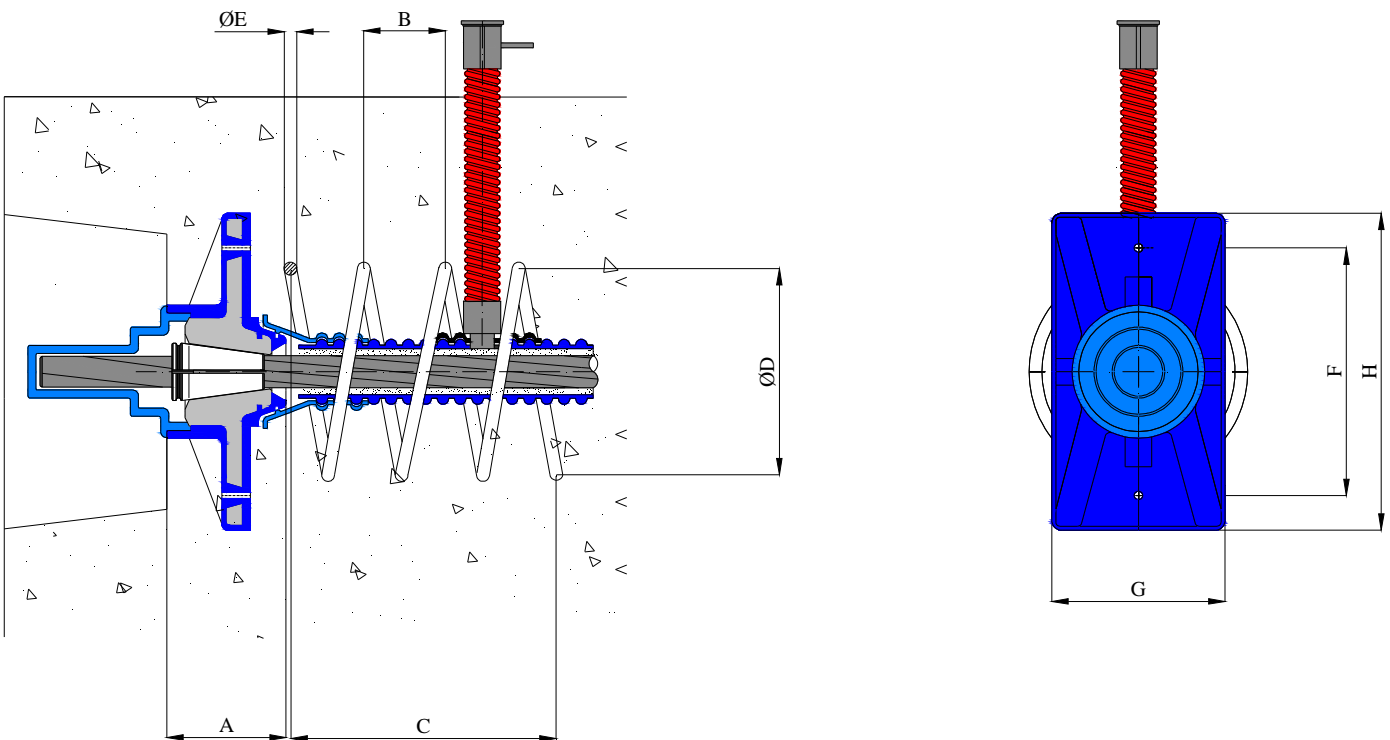

Type	Ultimate load			A	B	C	D	E	F	G	H
	T15 for cable (kN)	T15S for cable (kN)	T15C for cable (kN)								
1EX15-A6	259	279	307	60	40	130	110	6	130	85	155

"E" series 1E15-A7 single strand anchorages
(Bonded post-tensioning)



The anchorage: **active and bonded "1E15-A7"**. The application allows to install bonded single strand anchorages with the strand entered into a polyethylene sheath. This application is used in an environment that requires a simple protection of the "1E15-A7" anchorage by means of passivation while grouting and of the whole cable with a polyethylene sheath. The application is typical of industrial floors, diaphragms or slabs in a normal environment. This solution requires special tensioning jacks that can operate on a continuous cable. The cable is provided with a polyethylene protection sheath, which must be provided with proper grouting and vent points.

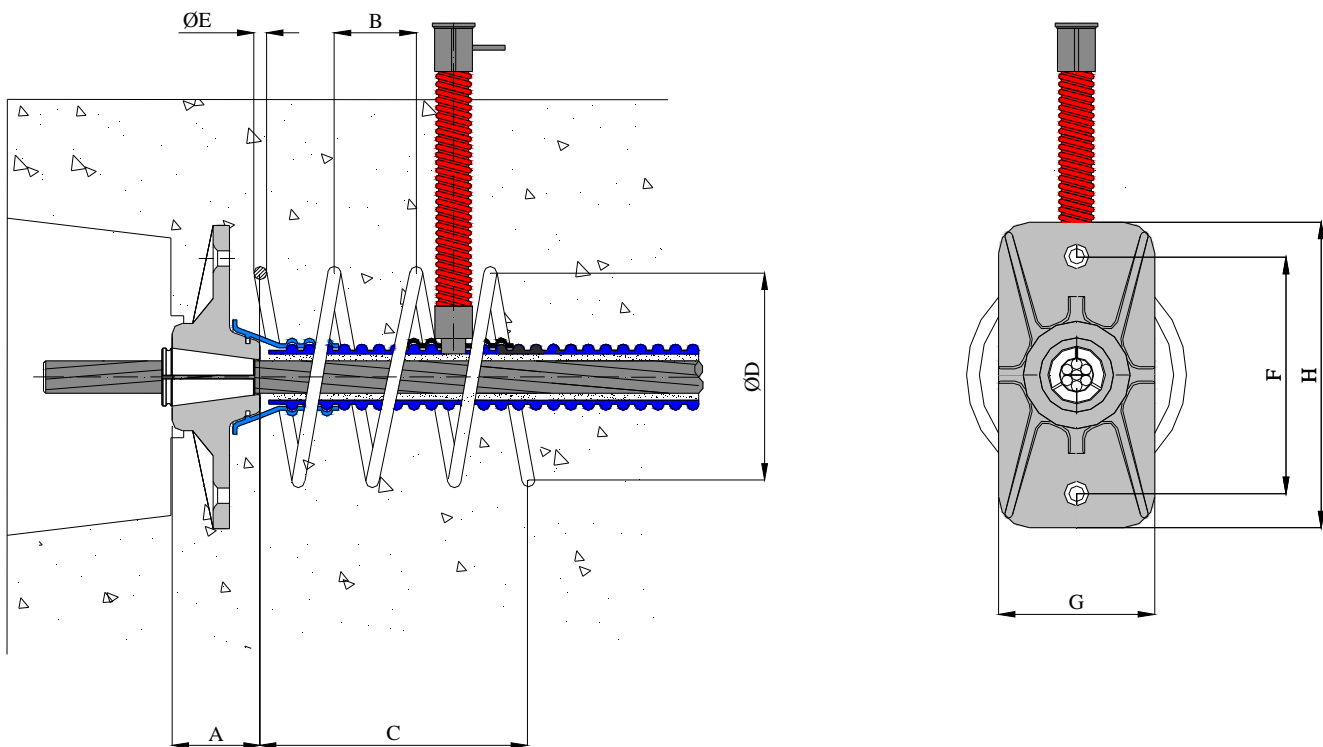

Type	Ultimate load			A	B	C	D	E	F	G	H
	T15 for cable (kN)	T15S for cable (kN)	T15C for cable (kN)								
1E15-A7	259	279	307	43	40	130	110	6	115	76	148

"EX" series 1EX15-A8 single strand anchorages
(Unbonded encapsulated post-tensioning)



The anchorage: **active, unbonded and encapsulated, "1EX15-A8" type**, it is made with the total encapsulation of the polyethylene covered anchorage, with the greased strand covered in polyethylene. The "1EX15-A8" anchorage is unbonded, it is supplied active (tensioning side) with truncated cone or rectangular pocket former to connect to the formwork. It is provided with a medium cap that may be installed after the strand, which is filled with grease, is cut. This application is typical of industrial floors, diaphragms or slabs in a highly aggressive environment for the whole system.

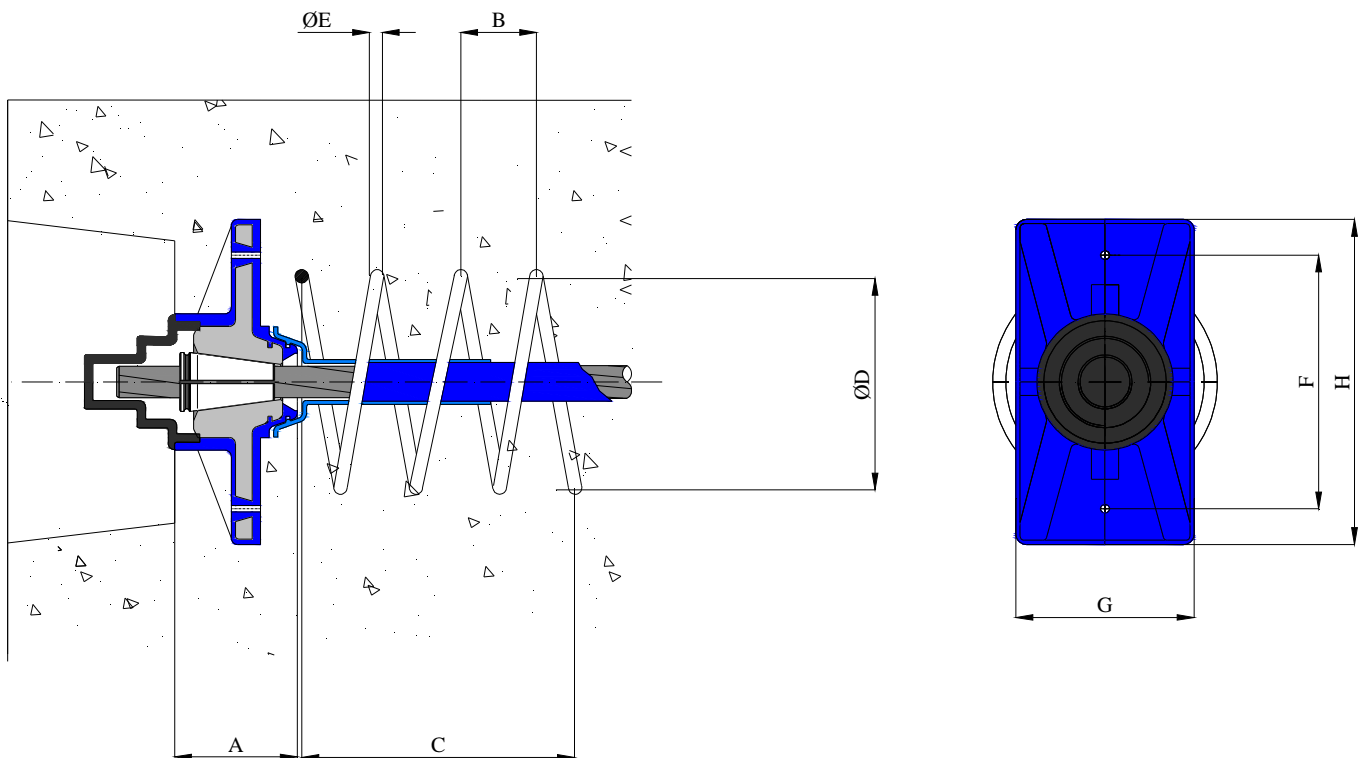

Type	Ultimate load			A	B	C	D	E	F	G	H
	T15 for cable (kN)	T15S for cable (kN)	T15C for cable (kN)								
1EX15-A8	259	279	307	60	40	130	110	6	130	85	155

"EX" series 1EX15-A9 single strand anchorages
(Unbonded encapsulated post-tensioning)



The anchorage: **active, unbonded and encapsulated, "1EX15-A9" type**. It is made with the total encapsulation of the polyethylene covered anchorage, with the greased strand covered in polyethylene. The "1EX15-A9" anchorage is unbonded, it is supplied active (tensioning side) with truncated cone or rectangular pocket former to connect to the formwork. It is provided with a short cap that may be installed after the strand, which is filled with grease, is cut. This application is typical of industrial floors, diaphragms or slabs in a highly aggressive environment for the whole system.

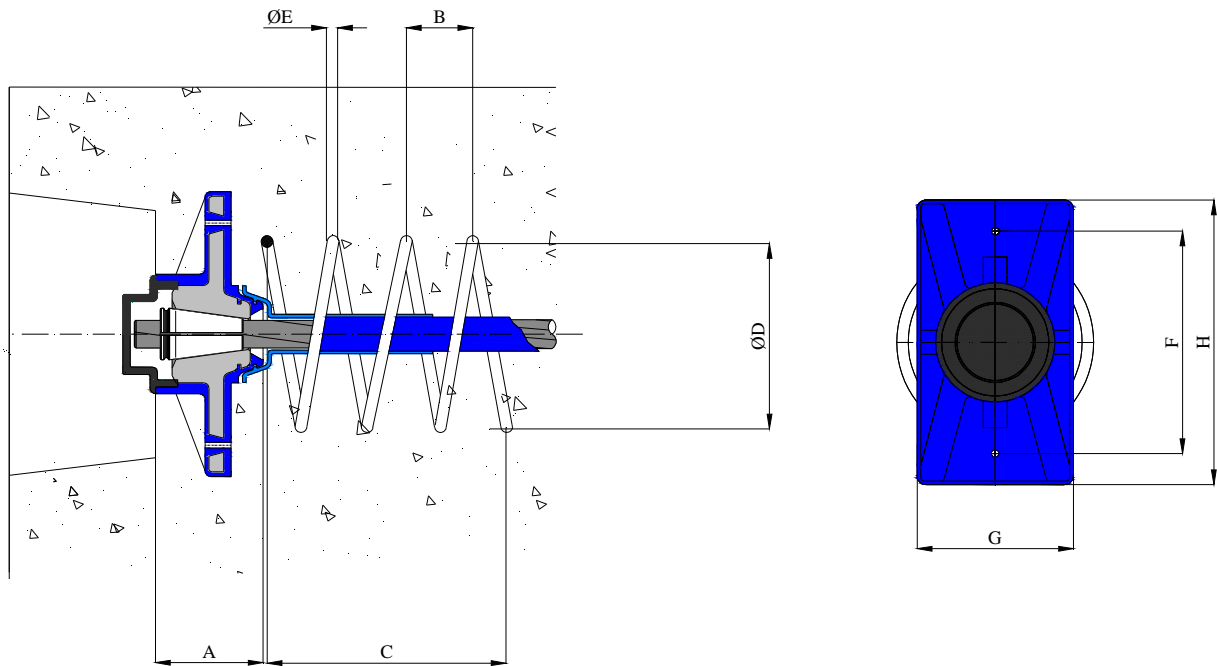

Type	Ultimate load			A	B	C	D	E	F	G	H
	T15 for cable (kN)	T15S for cable (kN)	T15C for cable (kN)								
1EX15-A9	259	279	307	60	40	130	110	6	130	85	155

"EX" series 1EX15-A10 single strand anchorages
(Encapsulated bonded post-tensioning)



The **active, unbonded and encapsulated "1EX15-A10"** anchorage is made with the total encapsulation of the anchorage and of the cable, protected with a polyethylene corrugated sheath. The **"1EX15-A10"** anchorage is bonded and grouted, it is supplied active (tensioning side) with truncated cone or rectangular pocket former to connect to the formwork. This application is typical of industrial floors, diaphragms or slabs in a highly aggressive environment for the whole system. The anchorage is provided with a medium cap that may be installed under pressure after the strand, which is filled with grease, is cut. The cable must be provided with proper grouting and vent points.

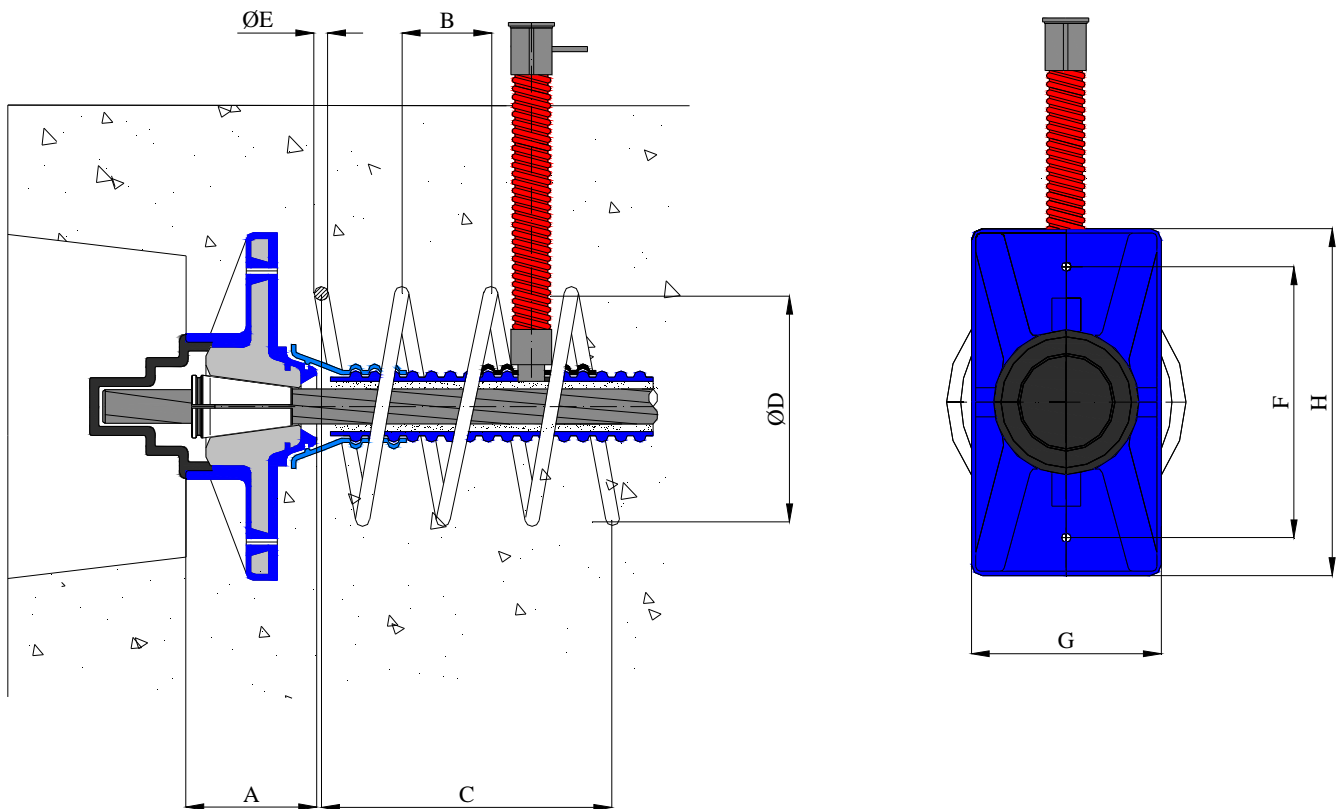

Type	Ultimate load			A	B	C	D	E	F	G	H
	T15 for cable (kN)	T15S for cable (kN)	T15C for cable (kN)								
1EX15-A10	259	279	307	60	40	130	110	6	130	85	155

"EX" series 1EX15-A11 single strand anchorages
(Encapsulated bonded post-tensioning)



The **active, unbonded and encapsulated "1EX15-A11"** anchorage is made with the total encapsulation of the anchorage and of the cable, protected with a polyethylene corrugated sheath. The **"1EX15-A11"** anchorage is bonded and grouted, it is supplied active (tensioning side) with truncated cone or rectangular pocket former to connect to the formwork. This application is typical of industrial floors, diaphragms or slabs in a highly aggressive environment for the whole system. The anchorage is provided with a short cap that may be installed under pressure after the strand, which is filled with grease, is cut. The cable must be provided with proper grouting and vent points.

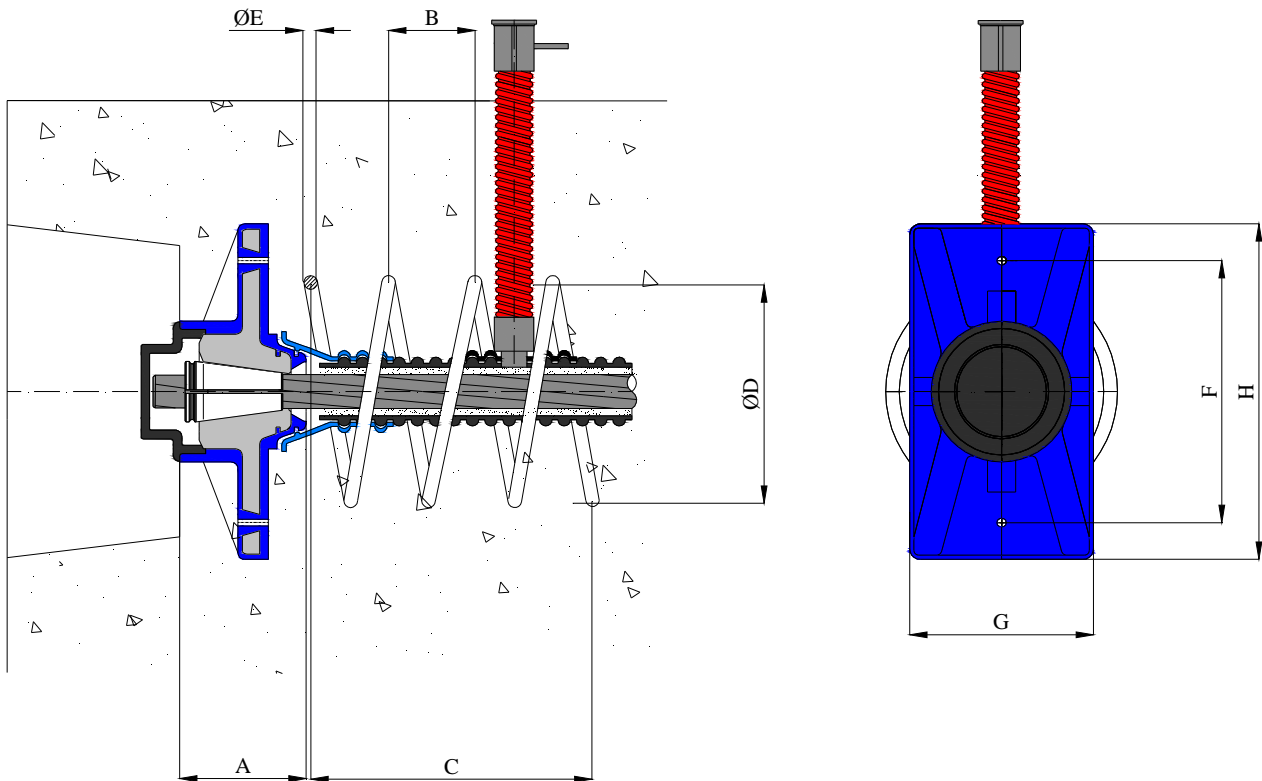

Type	Ultimate load			A	B	C	D	E	F	G	H
	T15 for cable (kN)	T15S for cable (kN)	T15C for cable (kN)								
1EX15-A11	259	279	307	60	40	130	110	6	130	85	155

"EX" series 1EX15-A12 single strand anchorages
(Encapsulated bonded post-tensioning)



The anchorage: **active and bonded, "1EXD15-A12" type**. It is made with the anchorage covered in polyethylene and entered into a metallic sheath. It is applied in an environment where a high anchorage protection is required, and where the cable protection is obtained by means of passivation while grouting. The **"1EX15-A12"** anchorage is bonded, it is supplied active (tensioning side) with truncated cone or rectangular pocket former to connect to the formwork. The application is typical of the carried-out industrial floors, diaphragms or slabs. The anchorage is provided with a threaded closing tip in order to guarantee a stronger closure to contain grease, it is provided with spring locking and can be installed on site by qualified technicians.

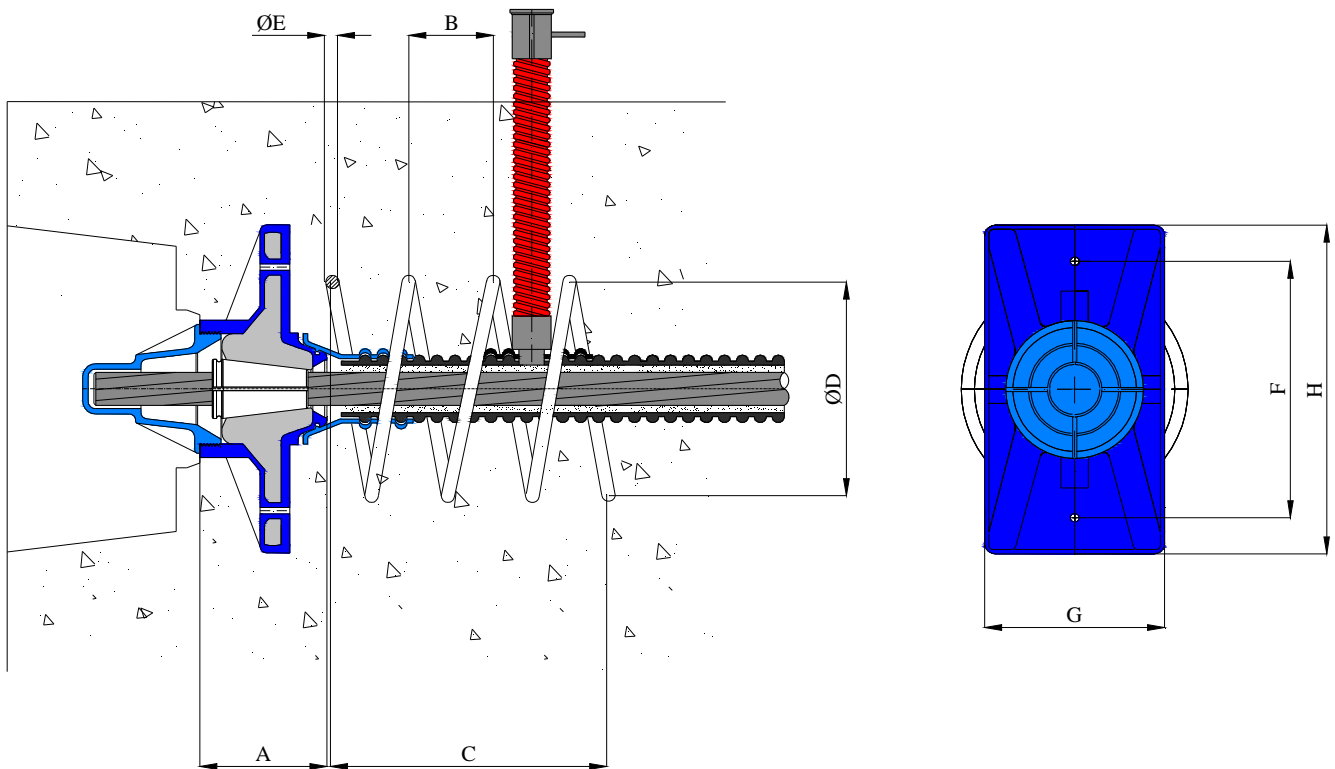

Type	Ultimate load			A	B	C	D	E	F	G	H
	T15 for cable (kN)	T15S for cable (kN)	T15C for cable (kN)								
1EX15-A12	259	279	307	60	40	130	110	6	130	85	155

"EX" series 1EX15-A13 single strand anchorages
(Bonded post-tensioning with encapsulated anchorage)



The anchorage: **active and bonded, "1EXD15-A13" type**. It is made with the anchorage covered in polyethylene and the strand entered into a metallic sheath. It is applied in an environment where a high anchorage protection is required, and where the cable protection is obtained by means of passivation while grouting. The **"1EX15-A13"** anchorage is bonded, it is supplied active (tensioning side) with truncated cone or rectangular pocket former to connect to the formwork. The application is typical of the carried-out industrial floors, diaphragms or slabs. The anchorage is provided with a pressure closing tip in order to guarantee a stronger closure to contain grease, it can be installed on site by qualified technicians.

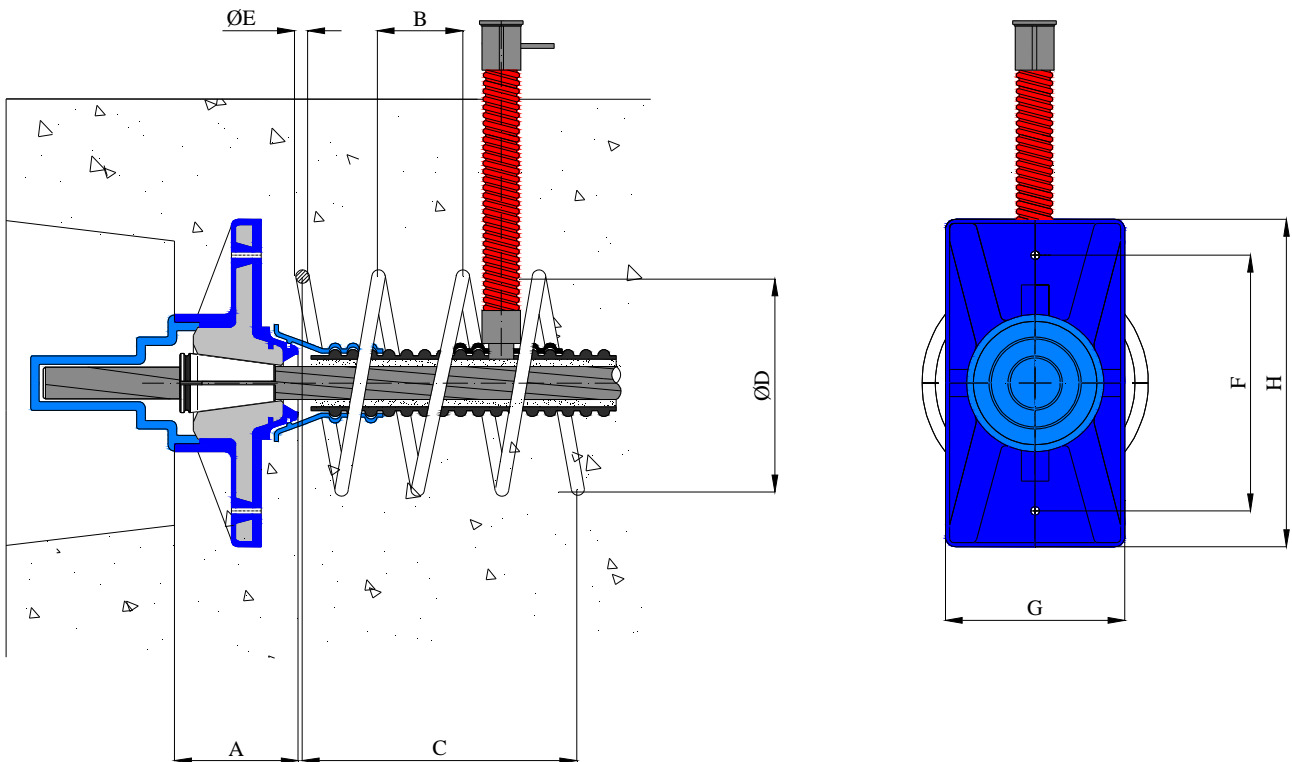

Type	Ultimate load			A	B	C	D	E	F	G	H
	T15 for cable (kN)	T15S for cable (kN)	T15C for cable (kN)								
1EX15-A13	259	279	307	60	40	130	110	6	130	85	155

"ED" series 1ED15-A14 single strand anchorages
(Bonded post-tensioning)



The anchorage: active and bonded, "1ED15-A14" type, it is supplied with the anchorage and the strand entered into a metallic sheath. It is applied in an environment where a unit protection is required by means of passivation while grouting. The **"1EX15-A14"** anchorage is bonded, it is supplied active (tensioning side) with truncated cone or rectangular pocket former to connect to the formwork. The application is typical of the carried-out industrial floors, diaphragms or slabs. The anchorage is provided with a threaded closing tip in order to guarantee a stronger closure to contain grease, it can be installed on site by qualified technicians.

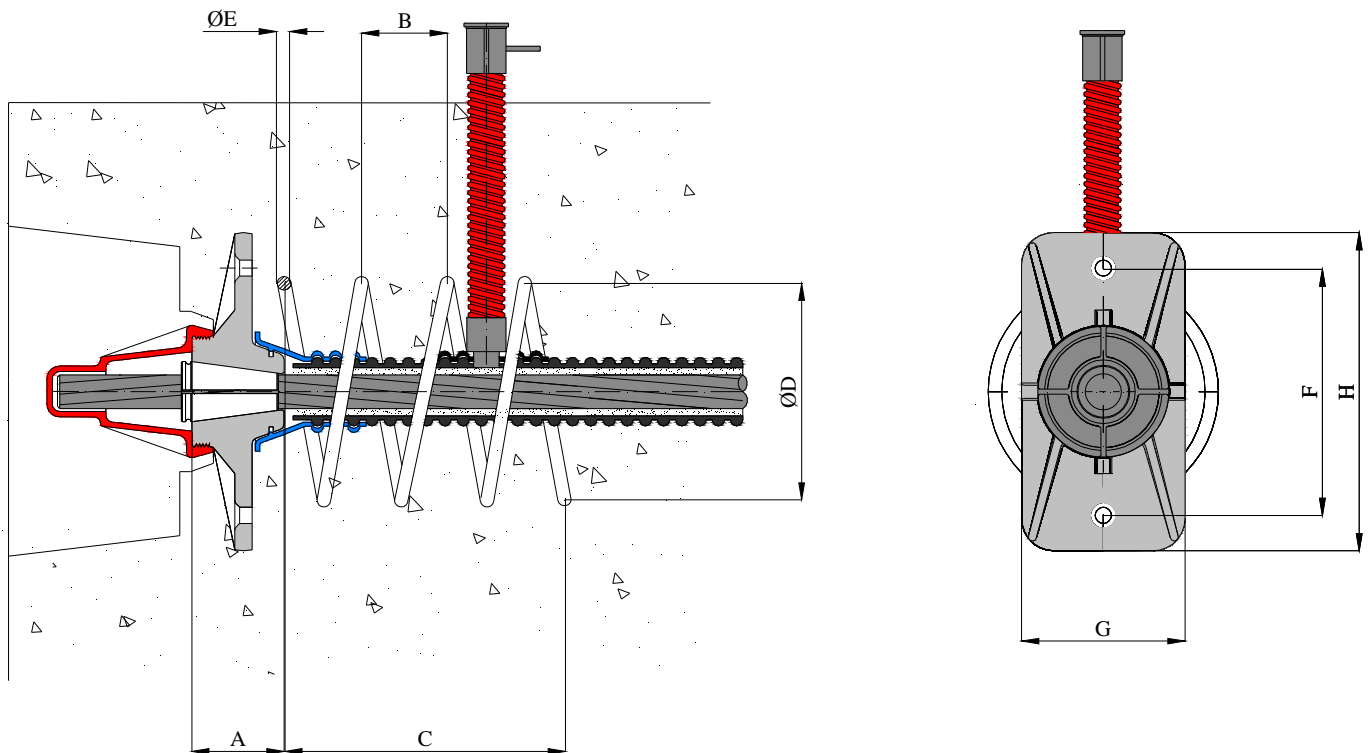

Type	Ultimate load			A	B	C	D	E	F	G	H	I
	T15 for cable (kN)	T15S for cable (kN)	T15C for cable (kN)									
1ED15-A14	259	279	307	43	40	130	110	6	115	76	148	77.5

"EX" series 1EX15-A15 single strand anchorages
(Bonded post-tensioning)



The anchorage: **active and bonded, "1EX15-A15" type**. It is made with the anchorage covered in polyethylene and entered into a metallic sheath. It is applied in an environment where a high anchorage protection is required, and where the cable protection is obtained by means of passivation while grouting. This application is typical of industrial floors, diaphragms and slabs. The "1EX15-A15" anchorage is bonded, it is supplied active (tensioning side) with truncated cone or rectangular pocket former to connect to the formwork. The anchorage is provided with a medium cap that may be installed under pressure after the strand, which is filled with grease, is cut. The cable must be provided with proper grouting and vent points.

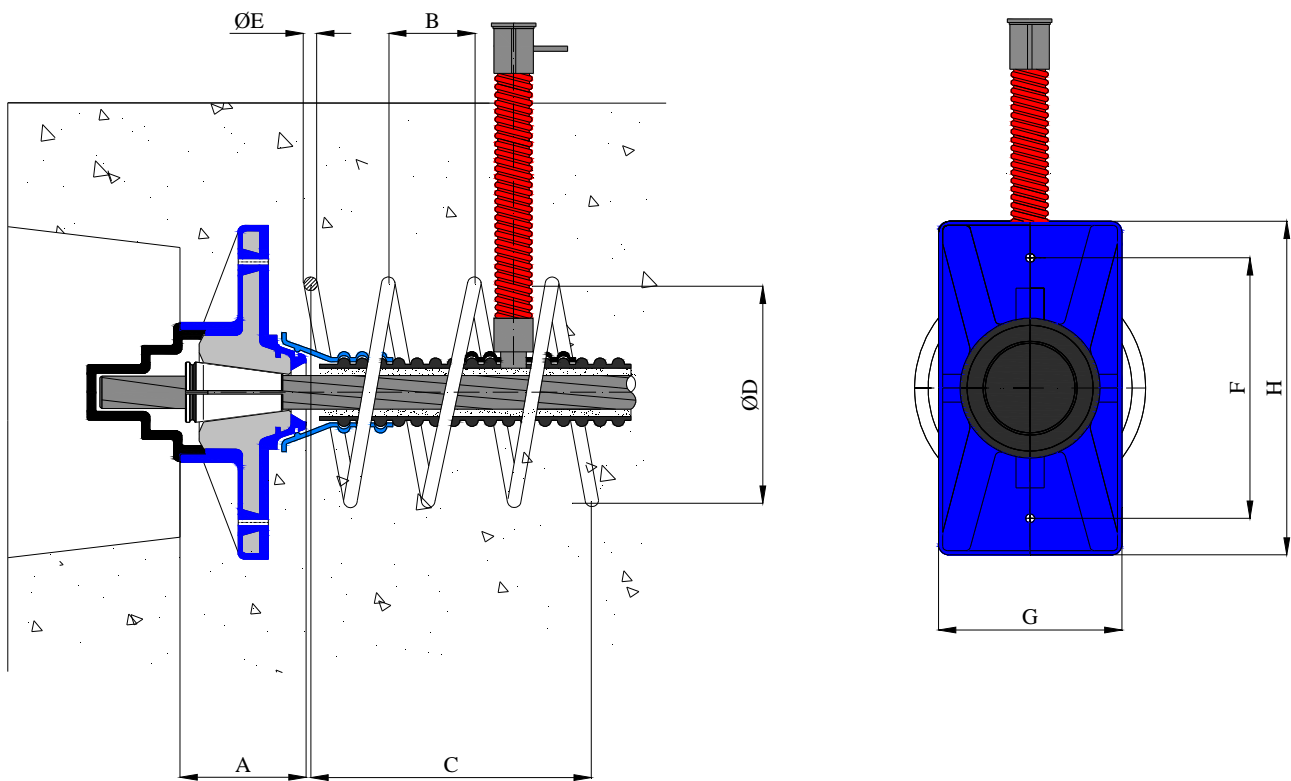

Type	Ultimate load			A	B	C	D	E	F	G	H
	T15 for cable (kN)	T15S for cable (kN)	T15C for cable (kN)								
1EX15-A15	259	279	307	60	40	130	110	6	130	85	155

"EX" series 1EX15-A16 single strand anchorages
(Bonded post-tensioning)



The anchorage: **active and bonded, "1EX15-A16" type**, is made with the anchorage covered in polyethylene and entered into a metallic sheath. It is applied in an environment where a high anchorage protection is required, and where the cable protection is obtained by means of passivation while grouting. This application is typical of industrial floors, diaphragms and slabs. The **"1EX15-A16"** anchorage is bonded, it is supplied active (tensioning side) with truncated cone or rectangular pocket former to connect to the formwork. The anchorage is provided with a short cap that may be installed under pressure after the strand, which is filled with grease, is cut. The cable must be provided with proper grouting and vent points.

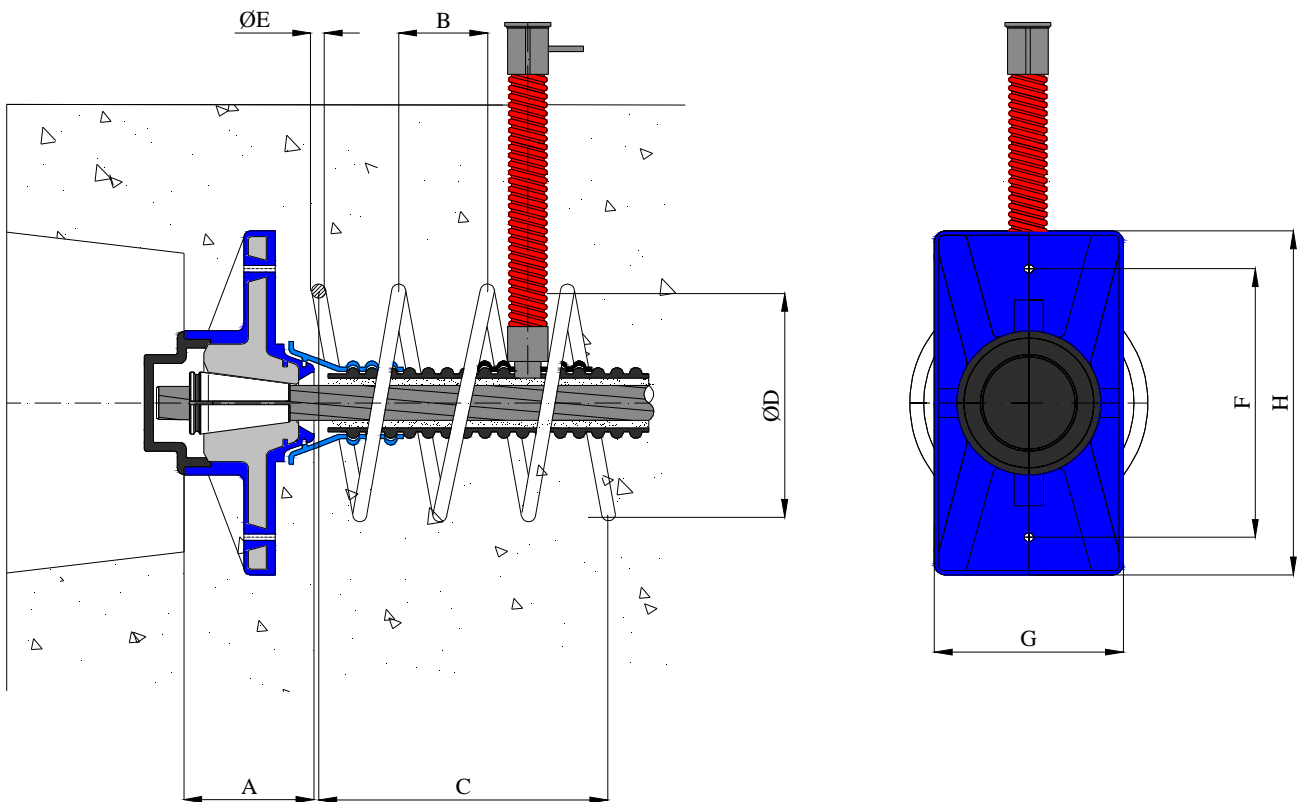

Type	Ultimate load			A	B	C	D	E	F	G	H
	T15 for cable (kN)	T15S for cable (kN)	T15C for cable (kN)								
1EX15-A16	259	279	307	60	40	130	110	6	130	85	155

"EXD" series 1EXD15-A17 single strand anchorages
(Bonded post-tensioning)



Anchoring: active member, such as "1EXD15-A17", the anchor is made of polyethylene covered and placed in a polyethylene conduit, application environments where high protection is required, the anchor and cable protection passivation obtained by the jet. The anchor "1EXD15-A17" is adherent, is provided on (stretching the side) for attachment to the mast step with conical or rectangular mold. The application is typical of industrial flooring, partitions or floors made. The anchorage is provided with a threaded closing tip in order to guarantee a stronger closure to contain grease, it can be installed on site by qualified technicians.

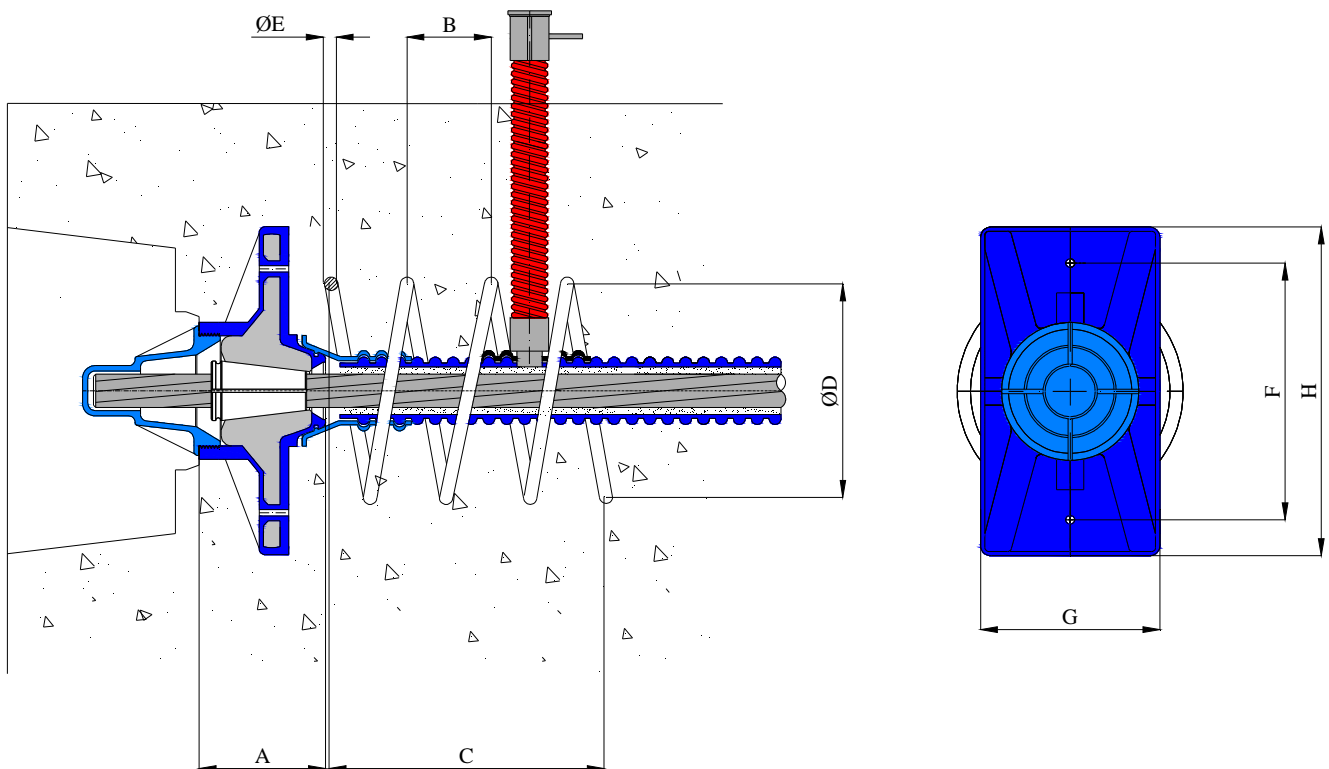

Type	Ultimate load			A	B	C	D	E	F	G	H
	T15 for cable (kN)	T15S for cable (kN)	T15C for cable (kN)								
1EXD15-A17	259	279	307	60	40	130	110	6	130	85	155

"ED" series 1ED15-A18 single strand anchorages
(Bonded post-tensioning)



Anchoring: active member, such as "1ED15-A18", is made with the anchor strand and inserted in a polyethylene conduit, application environments where protection is required in the casting complex obtained by passivation. The anchor "1ED15-A18" is adherent, is provided on (stretching the side) for attachment to the mast step with conical or rectangular mold. The application is typical of industrial flooring, partitions or floors made. The anchor has a threaded cap closure, which ensures a more energetic close to the containment of the fat, can be installed on site by qualified technicians.

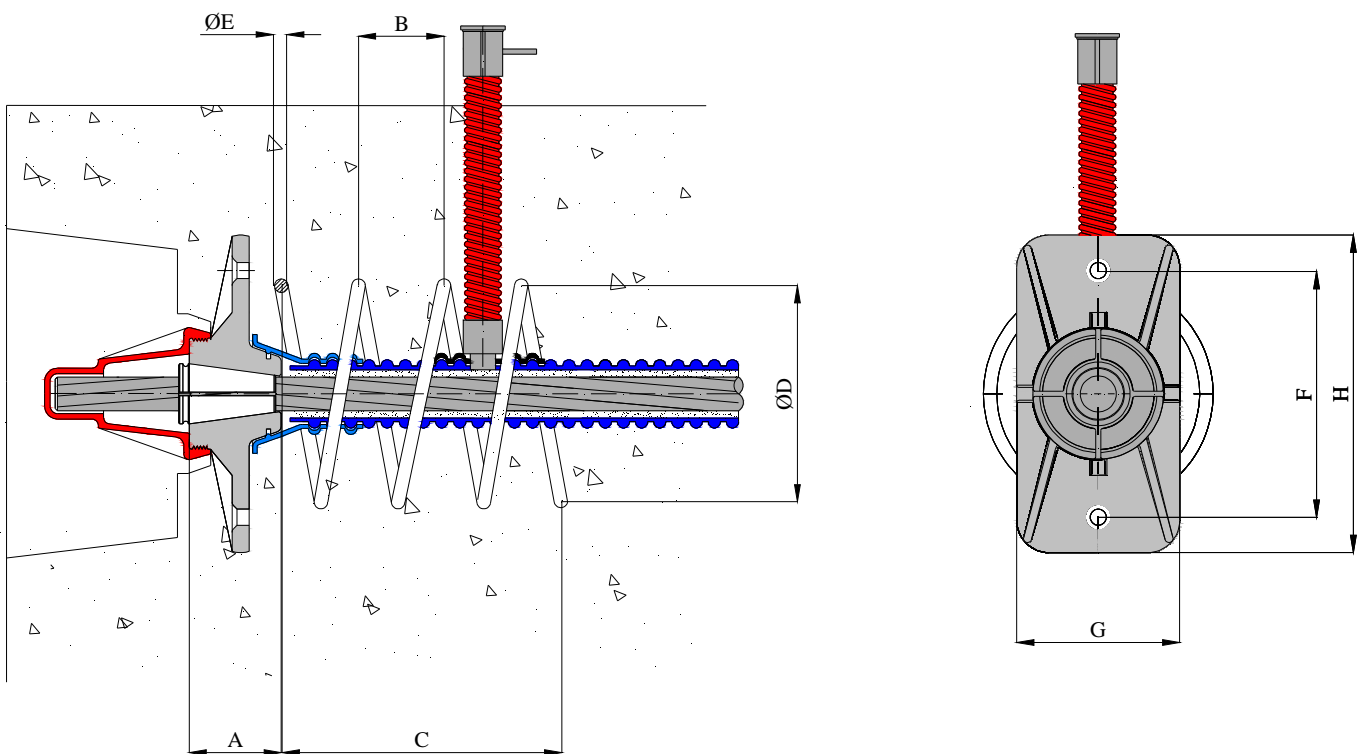

Type	Ultimate load			A (mm)	B (mm)	C (mm)	D (mm)	E (mm)	F (mm)	G (mm)	H (mm)
	T15 for cable (kN)	T15S for cable (kN)	T15C for cable (kN)								
1ED15-A18	259	279	307	43	40	130	110	6	115	76	148